

MU110-16R(K)

**Digital output module
16 channel**

User guide

Contents

1	Description	2
1.1	Functions	2
1.2	Modbus networking.....	2
1.3	Design.....	2
2	Specifications	4
2.1	Ordering information	4
2.2	Technical data	4
2.3	Environmental conditions.....	5
3	Safety	6
3.1	Intended use	6
4	Installation	7
4.1	Wiring.....	7
4.1.1	Hardware write protection.....	7
4.1.2	Outputs	7
5	Configuration	10
6	Operation	12
6.1	Functional test	12
6.2	Individual ON/OFF control	12
6.3	Individual control in PWM mode	12
6.4	Group control	13
6.5	Fault Condition.....	13
6.6	Memory addressing	13
7	Restore factory settings	15
8	Maintenance	17
9	Transportation and storage	18
10	Scope of delivery	19
	Appendix A Dimensions	20

Description

1 Description

1.1 Functions

Digital output module MU110-16R(K) is an extension module with 16 digital outputs.

The module provides following actions:

- connection of actuators with digital outputs
- output control using Modbus network
- pulse width modulation (see 6.3)
- network diagnostic
- fault and alarm signals
- Slave in a Modbus protocol structure.

The module uses Modbus-RTU and Modbus-ASCII protocols with automatic protocol identification.

The module is to be configured using 'M110 Configurator' software via RS485-USB interface adapter IC4 (not included). The latest version of the configuration software is available for download on www.akytec.de.

1.2 Modbus networking

I/O modules of series Mx110 use the common standard RS485 for data exchange.

Serial interface RS485 enables communication via two-wired line in half-duplex mode. Modules support Modbus RTU and Modbus ASCII protocols. The network consists of a Master device and can contain up to 32 Slave devices. Maximum length is 1,200 m. The number of Slave devices and network length can be increased using RS485 interface repeater.

Devices are connected to a network according to linear (bus) topology. It means that the line goes from the first device to the second one, from the second one to the third one, etc. Star connection and spur lines are not allowed.

Line reflections always occur at each of the 2 ends of the bus (the first and the last node). The higher the data transmission rate, the stronger they are. A terminating resistor is needed to minimize reflections. Line termination may be a 150 ohms value (0.5 W) resis-tor.

All modules can be used as Slave devices only. Master device can be PLC, computer with SCADA software or control panel.

1.3 Design

- | | |
|-------------------|---|
| – Enclosure | plastic, grey, for DIN-rail or wall mounting |
| – Terminal blocks | 2 plug-in terminal blocks with 24 screw terminals |
| – LED POWER | power supply indicator |
| – LED RS-485 | flashes at data exchange over serial port |
| – LED FAULT | lit when data exchange via serial port is interrupted |
| – 16 LEDs OUTPUTS | lit at logical 1 on the relevant output |

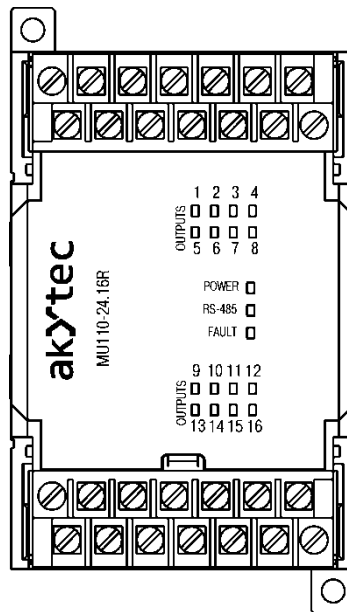

Fig. 1.1 Front view MU110-16R

Dimensional drawings are given in App. A.

Exterior of the device's front panel is shown on Fig. 1.1. There are three DIP switches under a module front cover (see Fig. 4.1):

- S1 – restore factory settings (see 7)
- S2 – service function
- S3 – DRAM write-protection (see 4.1.1)

All DIP switches are in OFF position by default.

Specifications

2 Specifications

2.1 Ordering information

Module MU110-16R(K) can be ordered in 2 modifications depending on the output type.

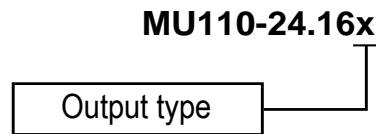

Fig. 2.1 Ordering code

Output type:

- R - relay outputs
- K - NPN transistor outputs

2.2 Technical data

Table 2.1 General data

Power supply		24 (20...28) V DC
Power consumption, max.		12 W
Inputs	Digital	–
	Analog	–
Outputs	Digital	16
	Analog	–
RS485 interface	Connection	D+, D-
	Protocols	Modbus RTU/ASCII
	Baud rate	2.4...115.2 kbit/s
	Data bits	7, 8
	Parity	odd, even, none
	Stop bits	1, 2
Dimensions		63 x 110 x 75 mm
Weight		approx. 300 g
Material		plastic

Table 2.2 Outputs data

Property	MU110-16R	MU110-16K
Output	relay (NO)	NPN transistor
Permissible load	3 A, 250 V AC, $\cos\varphi > 0.4$ or 30 V DC	400 mA, 60 V DC
Galvanic isolation	in groups of 4	in groups of 4

Specifications

2.3 Environmental conditions

The module is designed for natural convection cooling. It should be taken into account when choosing the installation site.

The following environment conditions must be observed:

- clean, dry and controlled environment, low dust level
- closed non-hazardous areas, free of corrosive or flammable gases

Table 2.3 Environmental conditions

Condition	Permissible range
Ambient temperature	-20...+55°C
Transportation and storage	-25...+55°C
Relative humidity	up to 80% (at +25°C, non-condensing)
IP code	IP20
Altitude	up to 2000 m above sea level

Safety

3 Safety

Explanation of the symbols and keywords used:



DANGER

DANGER indicates an imminently hazardous situation which, if not avoided, will result in death or serious injury.



WARNING

WARNING indicates a potentially hazardous situation which, if not avoided, could result in death or serious injury.



CAUTION

CAUTION indicates a potentially hazardous situation which, if not avoided, could result in minor or moderate injury.



NOTICE

NOTICE indicates a potentially harmful situation which, if not avoided, may result in damage of the product itself or of adjacent objects.

3.1 Intended use

The device has been designed and built solely for the intended use described in this guide, and may only be used accordingly. The technical specifications contained in this guide must be observed.

The device may be operated only in properly installed condition.

Improper use

Any other use is considered improper. Especially to note:

- This device should not be used for medical devices which receive, control or otherwise affect human life or physical health.
- The device should not be used in an explosive environment.
- The device should not be used in an atmosphere with chemically active substance.

Installation

4 Installation

 **WARNING**

Improper installation

Improper installation can cause serious or minor injuries or device damage. Installation must be performed only by fully qualified personnel

- The module is intended to be mounted in a cabinet on DIN-rail or on the wall. For the dimension drawings see Appendix A.
- Install the module in a cabinet with clean, dry and controlled environment. For further details see 2.3.
- The module is designed for natural convection cooling. It should be taken into account when choosing the installation site.

4.1 Wiring

Dangerous voltage

Electric shock could kill or seriously injure.

 **DANGER**

All electrical connections must be performed by a fully qualified electrician.

Ensure that the mains voltage matches the voltage marked on the nameplate!

Ensure that the device is provided with its own power supply line and electric fuse!

 **NOTICE**

Switch on the power supply only after wiring of the device has been completed.

- The electrical connections are shown in Fig. 4.1 and the terminal assignments in Table 4.1.
- Wiring options for both types of outputs are shown on Fig. 4.2–4.3.
- Connect the power supply to the terminals 24V /0V.
- The maximum conductor cross-section for power supply is 1.5 mm².

 **NOTICE**

Signal cables should be routed separately or screened from the supply cables.

 **NOTICE**

Only a shielded cable may be used for signal lines.

- Connect the RS485 lines to the terminals D+ and D-.
- Twisted pair cable should be used for the connection to RS485 interface.
Maximal cable length is 1200 m.

4.1.1 Hardware write protection

Data stored in permanent memory can be lost because of strong electromagnetic interference.

DIP-switch S3 (Hardware write-protection) can help to avoid data loss.

The following steps are required:

- Turn the power supply off;
- Open the front cover of the module (see Fig. 4.1)
- Set switch S3 to ON position.

Notice following:

- S3 switch is to be turned off again before changing the module parameters.

4.1.2 Outputs

- Module MU110-16R has 16 relay outputs, and MU110-16K has 16 NPN transistor outputs.
- Outputs can be controlled via RS485 network.

Installation

- Each output can be operated in pulse width modulation mode (PWM).
- Output technical data are shown in Tab. 2.2.

► NOTICE

Make sure that voltage and current on the outputs do not exceed maximum values even briefly.

If voltage rises, especially when inductive load (relay, coil etc.) is connected, keep the voltage peaks limited by protective measures.

- If there is inductive load on an NPN output, it is recommended to connect VD diode (100 V, 1 A) to protect the transistor (see Fig. 4.3).
- Outputs are 4-group isolated (1...4, 5...8, 9...12, 13...16). If connecting an inductive load, use only a common terminal (COMx) of the same group.
- In the module MU110-16K COMx are group negative terminals.

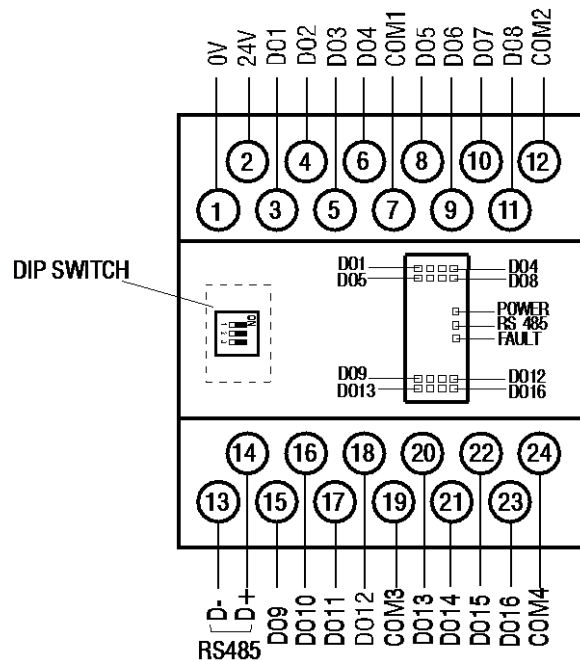

Fig. 4.1 Electrical connections

Table 4.1 Terminal assignments

No	Designation	Description	No	Designation	Description
1	0V	Power supply	13	D-	RS485 D-
2	24V		14	D+	RS485 D+
3	DO1	NO	15	DO9	NO
4	DO2	NO	16	DO10	NO
5	DO3	NO	17	DO11	NO
6	DO4	NO	18	DO12	NO
7	COM1	DO1...DO4	19	COM3	DO9...DO12
8	DO5	NO	20	DO13	NO
9	DO6	NO	21	DO14	NO
10	DO7	NO	22	DO15	NO
11	DO8	NO	23	DO16	NO
12	COM2	DO5...DO8	24	COM4	DO13...DO16

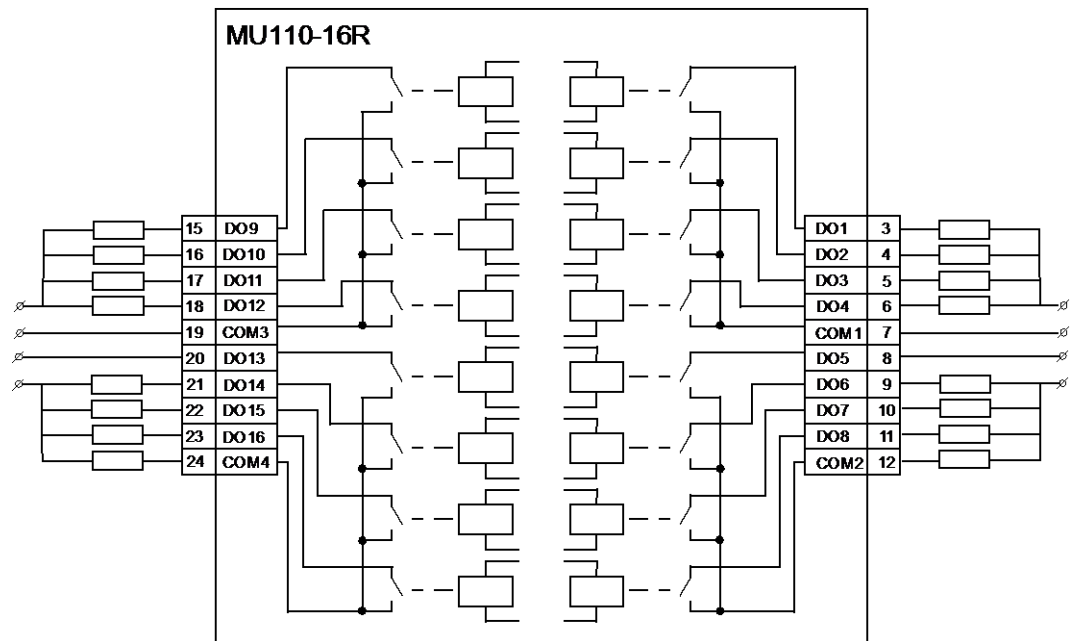

Fig. 4.2 MU110-16R outputs

If there is inductive load on an NPN output, it is recommended to connect VD diode (100 V, 1 A) to protect the transistor (see Fig. 4.3).

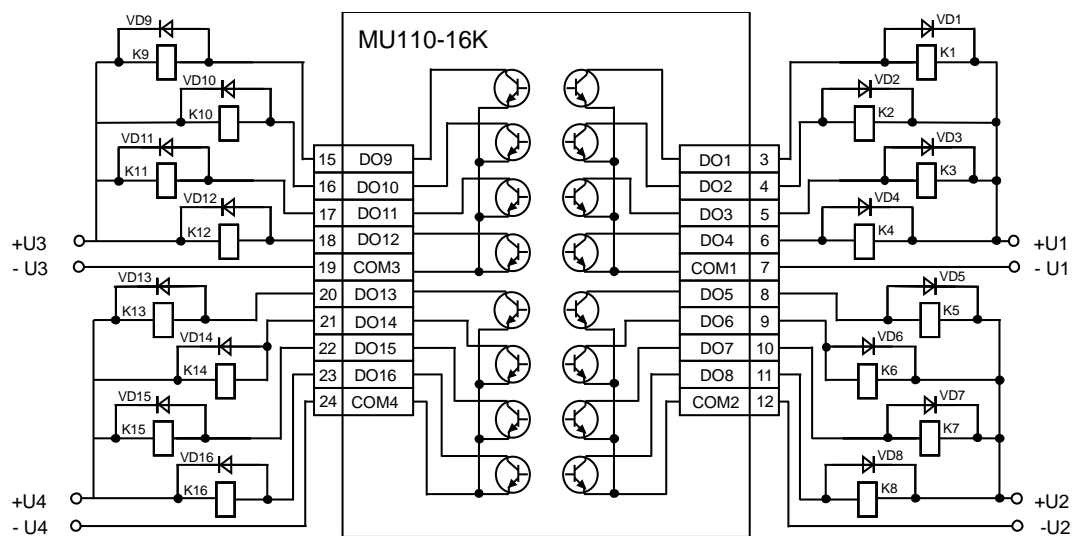

Fig. 4.3 MU110-16K outputs

Configuration

5 Configuration

► NOTICE

Before starting

Before switching on, make sure that the device was stored at the specified ambient temperature (-20 ... +55 °C) for at least 30 minutes.

Parameters of the module can be read, edited and saved with 'M110 Configurator' software. The full list of parameters is shown in the Table 5.1.

Module has to be configured first before operating in RS485 network.

The following steps are required:

- Install M110 Configurator on the PC.
- Connect the module to the USB interface of the PC over RS485-USB interface adapter IC4 (not included) Connect the D+/D- terminals of the module with the D+/D- contacts of the adapter.
- Connect the power supply to 24V/0V terminals of the module.
- Turn on the power supply.
- Run the M110 Configurator.

If the factory settings of the module have not been changed, the connection to the module is automatically established, the module automatically recognized, its configuration parameters read out and an appropriate configuration mask open.

If it does not happen, parameters of the configurator have to be changed.

Table 5.1 Configuration parameters

Name	Parameter	Valid value	Meaning	Default settings
Basic parameters				
dev	Device	Up to 8 symbols		MU110-16
ver	Firmware version	Up to 8 symbols		manufacturer
Network parameters				
bPS	Baud rate, kbit/s	0	2.4	9.6
		1	4.8	
		2	9.6	
		3	14.4	
		4	19.2	
		5	28.8	
		6	38.4	
		7	57.6	
		8	115.2	
LEn	Data bits *	0	7	8
		1	8	
PrtY	Parity *	0	none	none
		1	even	
		2	odd	
Sbit	Stop bits *	0	1	1
		1	2	
A.Len	Address bits	0	8	8
		1	11	
Addr	Device address	1...247		16

Configuration

Name	Parameter	Valid value	Meaning	Default settings
t.out	Time-out, s	0...600		0
Rs.dL	Response delay, ms	0...45		2
Output parameters				
THPD	PWM period, s	1...900	1...900	1
O.ALr	Safe output status, %	0...100	0...100	0

* Invalid network parameter combinations:

- *prty=0; sbit=0; len=0*
- *prty=1; sbit=1; len=1*
- *prty=2; sbit=1; len=1*

Operation

6 Operation

In the operation mode the module is controlled by a network Master in Modbus network. It can be performed in different ways:

- Individual control in digital mode (see 6.2)
- Individual control in PWM mode (see 6.3)
- Group control (see 6.4)

Modbus functions 03, 04 for reading and 15, 16 for writing can be used.

6.1 Functional test

To test the module for proper functioning the following steps are required:

- Connect the module to USB-port of the PC using a USB/RS485 adapter.
- Run M110 Configurator on the PC.
- If the connection has not been established automatically, the network parameters of the configurator have to be changed.
- Choose menu item ‘Device -> I/O status...’. A new window “Output status” will open.
- For each output the PWM duty cycle (pulse to period ratio) between 0 and 1 can be set, so that output is switched on/off or a continuous pulse train is generated.
- Output resistance for MU110-16R modification can be optionally measured with an ohmmeter.
- Max resistance on closed outputs - 1 ohm.
- Min resistance on open outputs - 2 Mohm.
- If there are any deficiencies in functioning, contact technical support of akYtec GmbH.

6.2 Individual ON/OFF control

Using Modbus function 15 (0x0F) ‘Write Multiple Coils’ certain outputs can be controlled.

Command includes:

- Start address (0x0000...0x000F)
- Number of bits (0x0001...0x0010)
- Number of bytes, n (0x01...0x02)
- Data (bitmask, n bytes)
- Addressing of individual cells is shown in the Table 6.3.

6.3 Individual control in PWM mode

Average voltage can be changed using pulse width modulation (PWM). Pulses with the specified period (parameter **THPD**) and the duty cycle (pulse to period ratio) are generated on the output.

Possible output statuses depending on duty cycle are shown in the Table 6.1. Modbus function 16 is to be used to transfer the duty cycle value to the module.

Table 6.1 Pulse width modulation

Duty cycle		Output status
Configuration	Modbus command	
0	0	0
1	1000	1
between 0 and 1	between 0 and 1000	between 0 and 1

Operation

- The configurator uses not the Modbus protocol but its own internal communication protocol. Therefore, range of value in configuration and in Modbus command can differ. For example, the duty cycle must be set to 1 for switching on the output DO1 during the functioning test. In a Modbus command the duty cycle must be written as 0001 in register 0000.
- The PWM period (**THPD**) is usually set during the configuration. The period can also be changed by a Modbus command, and the following should be noted:

Permanent memory

► NOTICE

As the permanent memory is not unlimited rewritable (approx. 10^6 times), it is not advisable to change the parameters ‘thpd’ (PWM period) and ‘o.alr’ (Safe output status) by Modbus commands as often as, for instance, PWM duty cycle.

- The minimum PWM period is 50 msec and cannot be changed.

6.4 Group control

Group control is performed using Modbus function 16. Thus the output status bitmask (see Tab. 6.2) has to be written into the register 50 (0x0032). This way all outputs can be controlled simultaneously. Bit 0 corresponds to the output 1.

With the transfer of the mask the generation of the pulse is stopped and the outputs are set in accordance with the mask.

6.5 Fault Condition

If the data exchange on the serial port is interrupted (i. e. there is no command from the master within the time specified by the parameter **t.out**) all outputs are set to a safe status. The ‘Fault Condition’ is a combination of all safe PWM duty cycle values, set in parameter **O.ALr** (Safe output status) for each output.

In this condition the following applies:

- LED FAULT flashes.
- A request from the master device terminates the Fault Condition.
- Outputs remain in the safe status until a command from the master changes the output status.
- If **t.out** parameter is set to 0, ‘Fault Condition’ is not defined.

Parameters **t.out** and **O.ALr** can be set during configuration or operation as well. The note ‘Permanent memory’ in sec. 6.3 should be taken into account.

6.6 Memory addressing

All variables and parameters in the Table 6.2 are of the type UINT16.

Variables in the Table 6.3 are of the type BOOL.

R – read access

W – write access

Table 6.2 Modbus register

Parameter	Unit	Value		Access	Address	
		Configuration	Modbus command		hex	dec
Duty cycle DO1	-	0...1	0...1000	RW	0000	0000
Duty cycle DO2	-	0...1	0...1000	RW	0001	0001
Duty cycle DO...	-	0...1	0...1000	RW
Duty cycle DO16	-	0...1	0...1000	RW	000F	0015
Safe output status (O.ALr) DO1	-	0...100	0...1000	RW	0010	0016

Operation

Parameter	Unit	Value		Access	Address	
		Configuration	Modbus command		hex	dec
Safe output status (O.ALr) DO2	-	0...100	0...1000	RW	0011	0017
Safe output status (O.ALr) DO...	-	0...100	0...1000	RW
Safe output status (O.ALr) DO16	-	0...100	0...1000	RW	001F	0031
PWM period (THPD) DO1	s	1...900	1...900	RW	0020	0032
PWM period (THPD) DO2	s	1...900	1...900	RW	0021	0033
PWM period (THPD) DO...	s	1...900	1...900	RW
PWM period (THPD) DO16	s	1...900	1...900	RW	002F	0047
Time-out (t.out)	s	0...600	0...600	RW	0030	0048
Output status bitmask	-	-	0...65535	RW	0032	0050

Table 6.3 Output status binary addresses for Modbus function 15

Output	Access	Address	
		hex	dec
1	W	0000	0000
2	W	0001	0001
...	W
16	W	000F	0015

Restore factory settings

7 Restore factory settings

If the communication between the module and PC cannot be established and network parameters of the module are unknown, the default network settings should be restored. The following steps are required:

- Turn off the power supply
- Remove a left front cover of the module
- Turn on DIP-switch S1. Module will operate with the default network parameters, the user settings remain stored.
- Turn on the power supply again



Dangerous voltage

The voltage on some components of the circuit board can be dangerous! Direct contact with the circuit board or penetration of a foreign body in the enclosure must be avoided!

- Run M110 Configurator
- In the window 'Connection to device' enter the values from the Table 7.1 or click the key 'Use factory settings' (see Fig. 7.1);

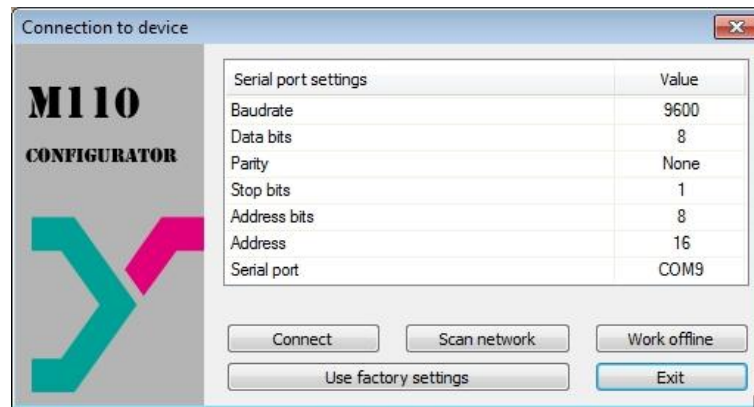

Fig. 7.1 M110 Configurator start window

- Click 'Connect' to establish the connection with factory settings.
- The main window of the Configurator opens. Saved user parameters of the module can be read now (see Fig. 7.2).
- Open folder 'Network parameters' and note the user network parameters.

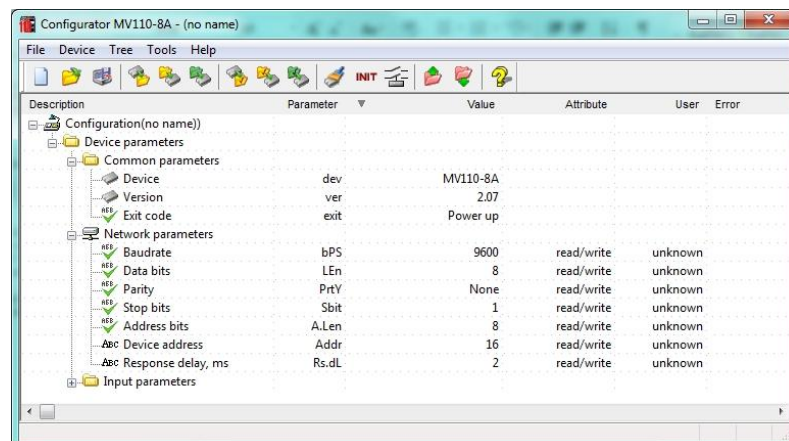

Fig. 7.2 M110 Configurator main window

- Close M110 Configurator
- Turn off the power supply

Restore factory settings

- Turn off DIP-switch S1
- Close the front cover
- Turn on the power supply again
- Start M110 Configurator
- Enter the noted network parameters
- Click 'Connect'.

The module is now ready for operation.

Table 7.1 Factory settings for network parameters

Parameter	Name	Factory setting
Baud rate	bPS	9600
Data bits	LEn	8
Parity	PrtY	None
Stop bits	Sbit	1
Address bits	A.Len	8
Address	Addr	16
Response delay, ms	Rs.dL	2

Maintenance

8 Maintenance

The maintenance includes:

- cleaning of the housing and terminal blocks from dust, dirt and debris
- checking the fastening of the device
- checking the wiring (connecting leads, fastenings, mechanical damage).

The device should be cleaned with a damp cloth only. No abrasives or solvent-containing cleaners may be used. The safety information in section 3 must be observed when carrying out maintenance.

Transportation and storage

9 Transportation and storage

Pack the device in such a way as to protect it reliably against impact for storage and transportation. The original packaging provides optimum protection.

If the device is not taken immediately after delivery into operation, it must be carefully stored at a protected location. The device should not be stored in an atmosphere with chemically active substances.

Permitted storage temperature: -25...+55 °C

► NOTICE

Transport damage, completeness

The device may have been damaged during transportation.

Check the device for transport damage and completeness!

Report the transport damage immediately to the shipper and akYtec GmbH!

Scope of delivery

10 Scope of delivery

- Module MU110-16R(K) 1
- Short guide 1

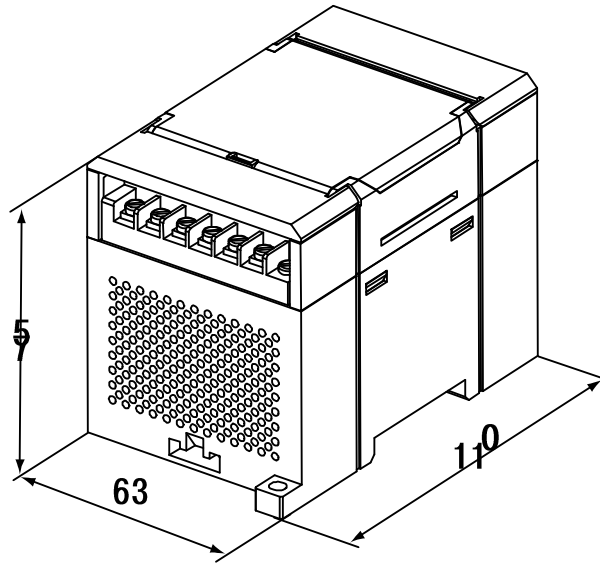

Fig. A.1 External dimensions

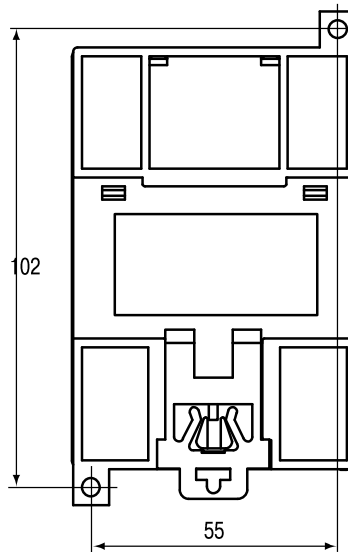

Fig. A.2 Wall mounting dimensions

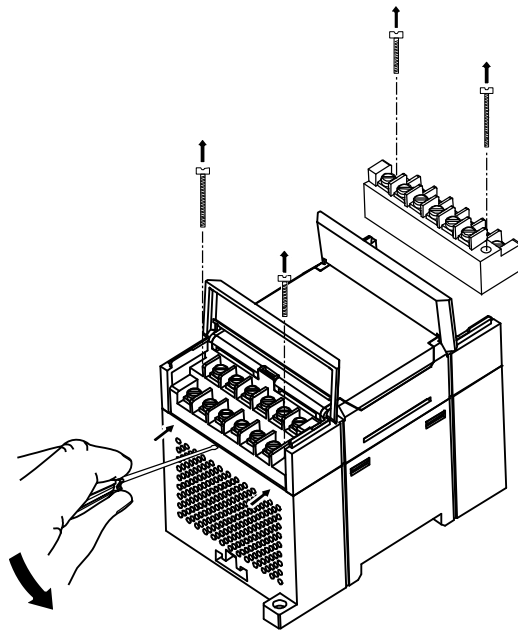

Fig. A.3 Replacement of terminal blocks